

hinging wings or webbing backrest between cabin bulkheads

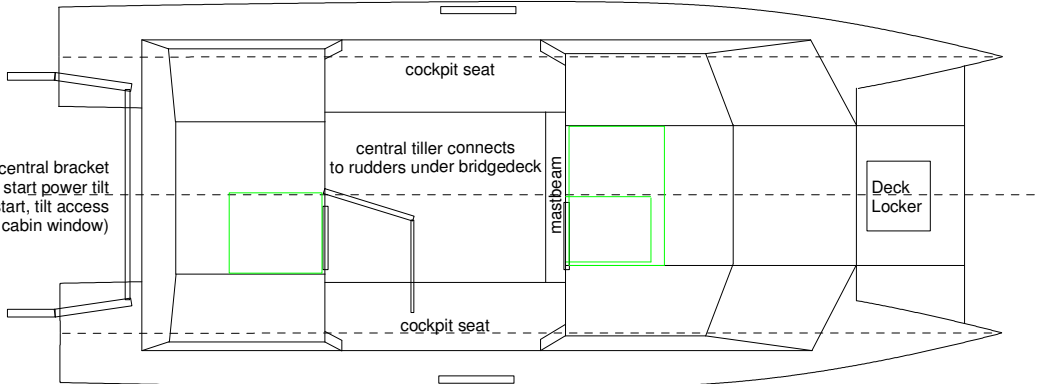

Engine on central bracket electric start power tilt (or hand start, tilt access through aft cabin window)

mast steps on cockpit floor for easy raising

green lines hatches, big lifting hatch in forward cabin

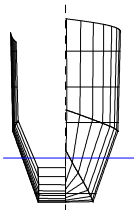
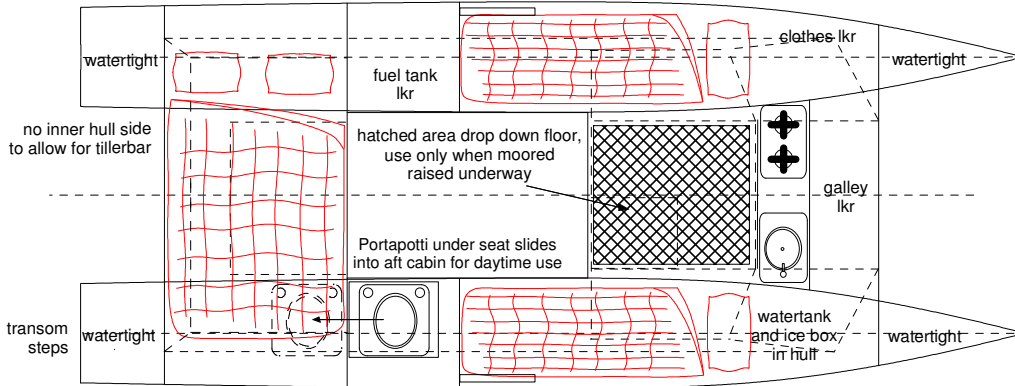

Provisional unfaired linesplan

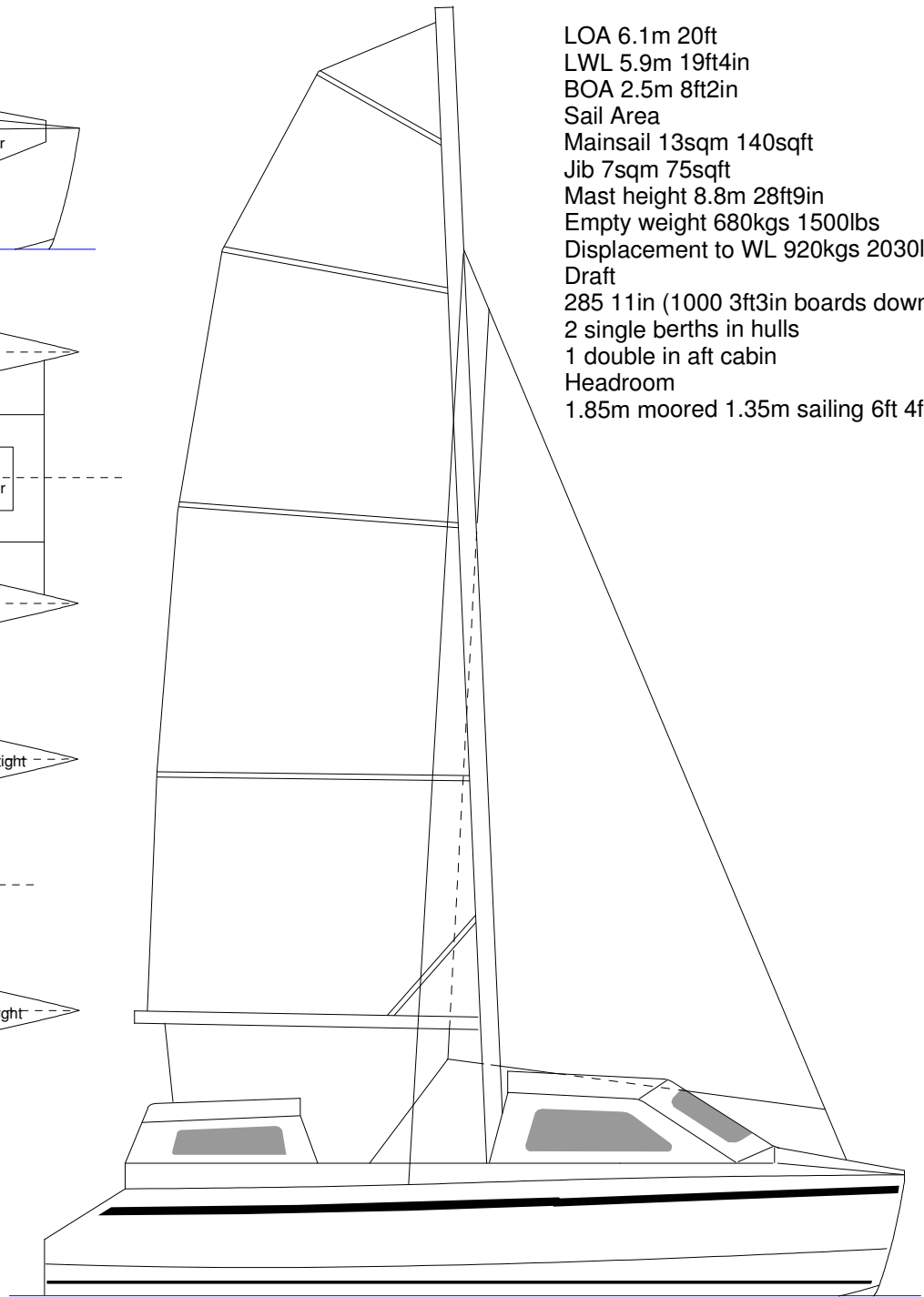
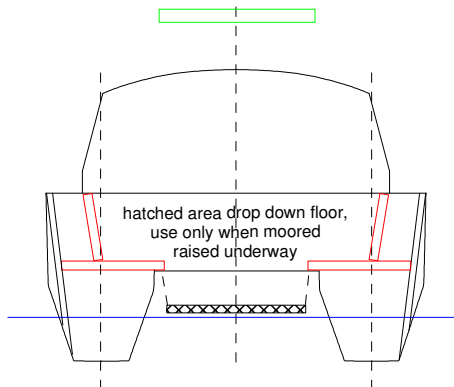

LOA 6.1m 20ft
 LWL 5.9m 19ft4in
 BOA 2.5m 8ft2in
 Sail Area
 Mainsail 13sqm 140sqft
 Jib 7sqm 75sqft
 Mast height 8.8m 28ft9in
 Empty weight 680kgs 1500lbs
 Displacement to WL 920kgs 2030lbs
 Draft
 285 11in (1000 3ft3in boards down)
 2 single berths in hulls
 1 double in aft cabin
 Headroom
 1.85m moored 1.35m sailing 6ft 4ft6in

Motor sailer catamaran for sheltered water sailing
 Simple sheet ply/epoxy construction
 Trailable with no folding