

Note: If longer windscreen made board can be inserted by angling in from aft check on own boat

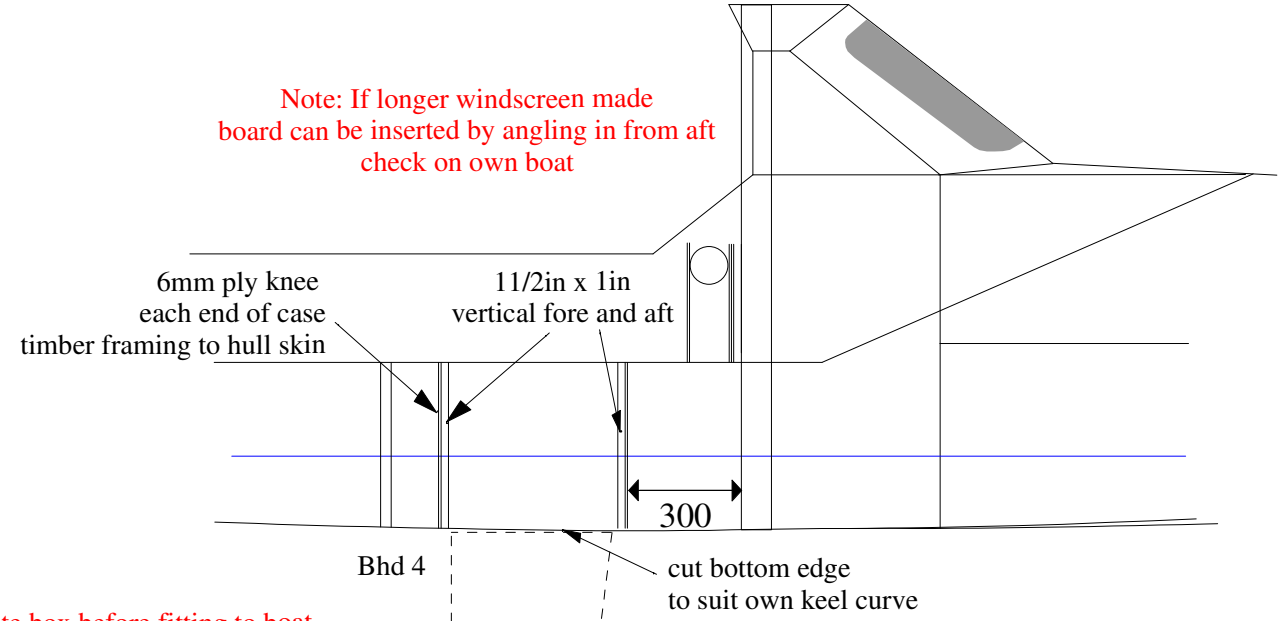

assemble complete box before fitting to boat glue and screw from underside use lots of filled epoxy not all framing shown, use 1 1/2in x 1in unless stated Ensure case is parallel to hull CL top and bottom

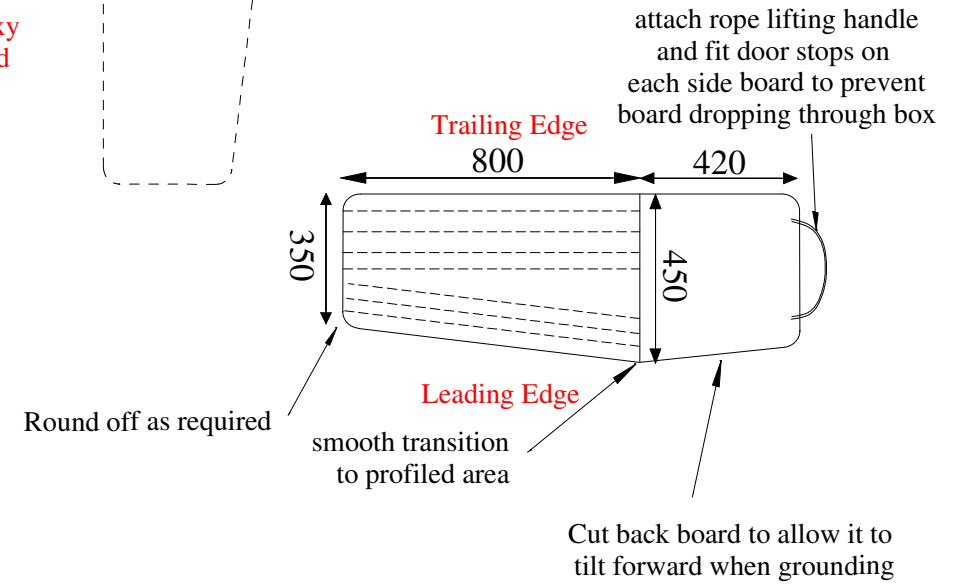
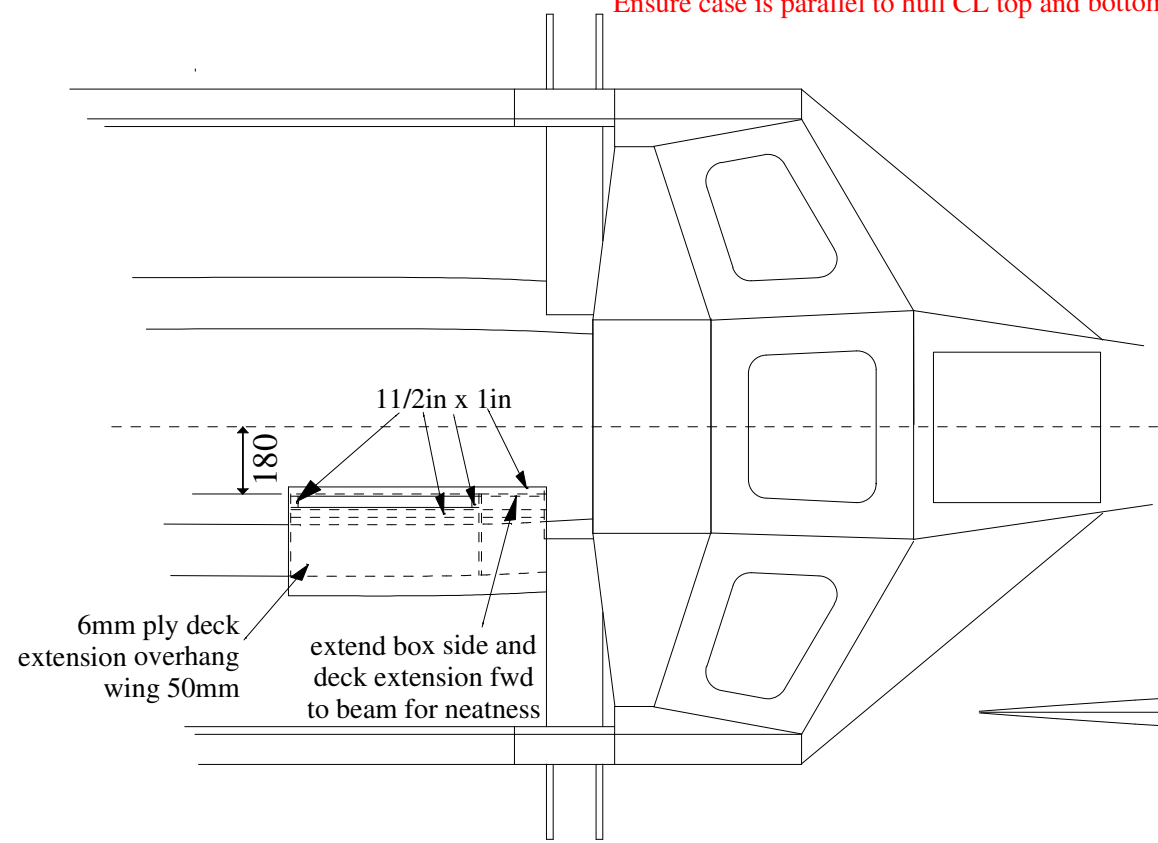

Cut out board blanks from 12mm ply. Glue together ensuring board does not twist. Once glue has fully cured plane/sand to shape. Sheath with glass/epoxy (doubled at keel exit area for 300mm) Board control as shown



Typical cross section daggerboard